

6KW E-Gas Hot Water & Warm Air Integrated Heater

Technical Description, Installation, Operation and Maintenance Instructions

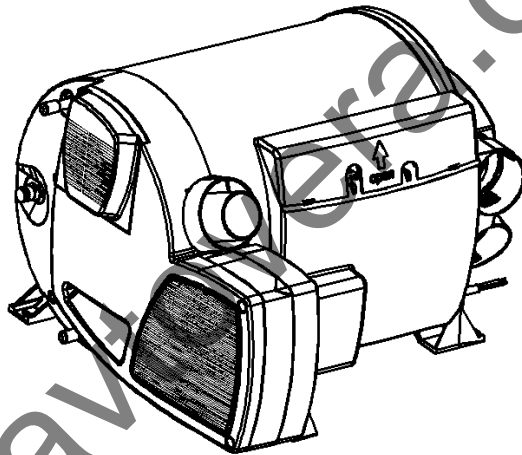

Production Type

Order No.

Liquefied gas electric heating DC12V/220VAC

4W2005 12C11

Version: Oct 15, 2018

Foreword

Thank you for using the Belief parking heater

This manual describes the technical description, installation, operation and maintenance instructions for the parking heater. To ensure the correct use of the heater please read this manual carefully before installation and use. Please keep it properly after reading it. For review.

Note:

- The contents of this manual are subject to change without prior notice, but the instructions are guaranteed to be consistent with the products purchased.
- we try our best to express the problems that users should know through the instructions. If you have questions or find something wrong, please contact us directly.
- When the user unpacks for the first time, check the main unit and accessories against the packing list. If you find any problems, please contact the dealer immediately.
- If there is a problem in use, please contact the company's marketing department or our authorized customer service station. We will be happy to help you.

Please carefully save the after-sales service warranty sheet and provide feedback as required.

This sheet is the only valid proof of after-sales service.

Note:

Must be installed and used in accordance with the requirements of the manual to ensure long-term use of the product!

1. Application

YFY-6E/1 Model gas heater (hereinafter referred to as heater) is a special heater for caravan that integrates hot water and warm air. This heater cannot be used in bus or dangerous goods carriers.

2. Main Technical Data

Rated Voltage	DC12V		
Operating Voltage Range	DC10.5V~16V		
Short-term Maximum Power Consumption	5.6A		
Average Power Consumption	1.3A		
Gas Heat Power (W)	2000	4000	6000
Fuel Consumption (g/H)	160	320	480
Gas Pressure	30mbar		
Warm Air Delivery Volume m ³ /H	287max		
Water Tank Capacity	10L		
Maximum Pressure of Water Pump	2.8bar		
Maximum Pressure of System	4.5bar		
Rated Electric Supply Voltage	~220V		
Electrical Heating Power	900W	1800W	
Electrical Power Dissipation	3.9A	7.8A	
Working (Environment) Temperature	-25°C~+80°C		
Working Altitude	≤1500m		
Weight (Kg)	15.6Kg		
Dimensions (mm)	510×450×300		

Table 1

3. Function

The heater is a hot water and warm air integrated machine, which can provide domestic hot water while heating the

occupants. This heater allows use during driving. This heater also has the function of using local electricity heating.

In hot water warm air work mode, this heater can be used to heat both the room and the hot water. If only hot water is needed, please choose hot water working mode.

When the ambient temperature is below 3° C, please empty the water in the water tank to prevent freezing of the water tank.

There are three energy options to choose from:

— Gas Mode

Heater automatic adjust the power.

—Electrical Mode

Manually select the 900W or 1800W heating mode according to the power supply capacity of the RV camp.

—Hybrid Mode

When the power demand is low (for example, maintaining the room temperature stage), the electrical heating is preferred. Until the city electricity cannot meet, the gas heating is started, and the gas heating function is turned off first in the power adjustment phase.

In hot water working mode, gas mode or electrical mode is used to heat the tank. The tank temperature can be set to 40° C or 60° C.

— Gas Mode

The heater operates at the lowest power. Stop heating immediately after reaching the set temperature.

—Electrical Mode

Manually select the 900W or 1800W heating mode according to the power supply capacity of the camp site.

4. Safety Instructions

The gas obtained from the liquefied gas tank is mandatory to be in a gaseous state. Liquefied gas is not allowed to avoid danger.

If a gas leak occurs or smells of gas:

- Immediately extinguish the open flame
- Open doors and windows
- Close all valves, liquefied gas tanks
- No smoking
- Do not operate any electrical switches
- Ask the professional to thoroughly check the gas system

5.Heater Installation

The typical installation of the heater is shown in

Figure 1.

- Modification of exhaust lines and accessories
- Do not follow the operating installation instructions
- Do not use our company's special accessories

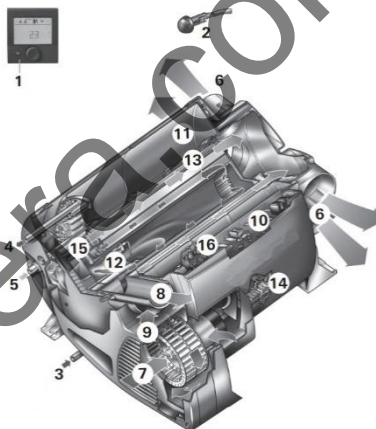

Figure 2

Figure 1

- 1- LCD control switch
- 2- External temperature sensor
- 3- Recirculating air inlet (minimum 150cm2)
- 4- Heat pipe
- 5- Heat outlet
- 6- Smoking cowl

★ Must be installed and repaired by professionals authorized by the company!

The company does not bear any responsibility for the following acts:

- Modified heater and accessories

Figure 3.

1_12V Power cord 2_LCD switch Lead wire 3_LCD switch back cover 4_LCD switch bracket 5_Cross head self-tapping nail M3*10 6_LCD control switch 7_Cross countersunk head flat tail self-tapping nail M3*6 8_Cross head self-tapping ST5*25 9_Heater 10_Controller cover 11_External temperature sensor lead wire 12_External temperature sensor 13_φ8 Elbow transition fitting 14_Rubber strip clamp 15_ Cross pan head self-tapping screws ST5×16 16_φ8 Straight transition fitting 17_Precision tube 18_Fitting nut M14*1.5 19_Ferrule 20_φ10 Hose (gas) transition fitting 21_φ10 Steel (water) pipe elbow transition fitting 22_Hose(water) transition fitting 23_Intake pipe mounting clamp 24_Cross pan head tapping screw ST3.5×25 25_Air intake pipe 26_German type clamp 27_ Exhaust pipe 28_Sealing rubber spacer 29_(Exhaust pipe) clamp 30_Intake and exhaust combine cowl 31_Intake and exhaust combine cover 32_Air outlet 33_Hot air tube 34_Bellows buckle 35_T-fitting 36_φ60 connecting pipe 37_φ60 elbow fitting A-connect to 12V Battery B- connect to gas adjust valve C- connect to water equipment D-connect to system water tank E-hook , clamp LCD switcher cord

The heater installation location should be selected from load-bearing floor, double floor or underfloor.

If there is no suitable floor, you can first make a load bearing surface with plywood.

★The heater must be firmly fixed to the mounting surface with screws to prevent damage to the gas pipeline during driving and cause danger.

Depending on the actual installation, may only install three screws. Two die-cast aluminum fixing screws are fixed then choose a plastic right angle to fix it.

To ensure that the heater evenly distributes heat, the heater should be installed in the center as much as possible to ensure that the heating circuit is equal long as possible.

No cover is allowed to add to the heater surface.

★ The exhaust cowl must be on the side wall or ceiling.

In the exhaust cowl installed area, there is no ventilation window in the range of 300mm, and there is no refueling port or tank respirator in the range of 500mm.

The exhaust cowl is mounted below the window that is close to or openable. A window switch should be installed to ensure that the heater is turned off automatically when the window is opened.

Air Inlet Hose Installation

The exhaust pipe is pass through the intake pipe. The length of the intake and exhaust pipe is as shown in Fig. 6, and the shortest is 60cm and the longest is 100cm. The exhaust cowl is only allowed under the exhaust outlet 20cm.

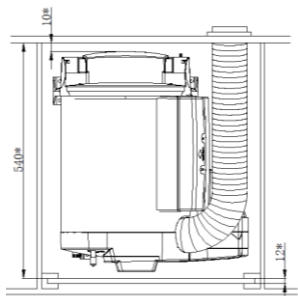

Figure 4

The size with* is the smallest size, leaving enough space to connect accessories such as gas and water pipes.

To prevent the danger from heater accidentally loosening, the upper cover of the heater compartment is screwed to the upper cover (Figure 4-1). Next to the installation location it is necessary to install a strong partition strip in front of the heater, perpendicular to the direction of travel. Above the floor height 180mm can be attached to a septum (minimum 30*50mm).

Heat sensitive objects and flammable objects should be placed away from the heater.

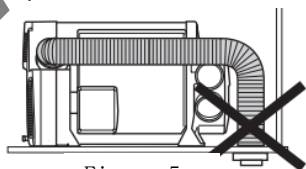

Figure 5

Figure 6

After the intake and exhaust pipes are pierced from the through holes, they must be cut short, and the exhaust pipes are slightly shorter than the intake pipes. Avoid excessive expansion or tension on the exhaust pipe.

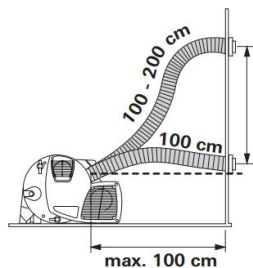

Figure 7

The length of the intake and exhaust pipes is 100 cm to 200 cm, as shown in Figure 7. The piping must be arranged in the ascending direction.

The Exhaust Cowl (air inlet and outlet) Installation

Select a flat mounting surface so that combustion air can enter from all sides. Drill one hole of $\phi 83$. Seal (Fig. 8-8), with the plane facing the exhaust cowl. Wear the fixing clip before installing the exhaust pipe (Figure 8-3). Pay attention to the installation of the smoke cap upwards.

20mm at the end of the exhaust pipe should be compressed, do not straighten. Insert the exhaust pipe into the exhaust cowl interface (Figure 8-10), as deep as possible. Try to fix the clips on the top, tighten.

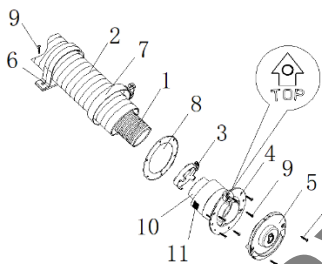

Figure 8

Place the air intake pipe (Figure 8-2) over the exhaust cowl tooth (Figure 8-11). Set on the fixed clip (Figure 8-7), tighten.

Secure the exhaust cowl with 6 screws (Figure 8-9).

Use 2 screws to fix the exhaust cowl.

Fix the exhaust pipe on the side wall with mounting clip.

Connect Air Inlet Pipe to The Heater

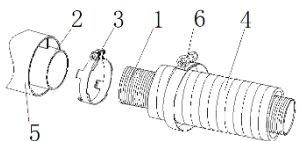

Figure 9

20mm at the end of the exhaust pipe should be compressed, do not straighten.

Try to insert the exhaust pipe on exhaust port as deep as possible. fix the clip on top, tighten.

Place the air intake pipe (Figure 9-3) over the inlet port (Figure 9-5). Set on the fixed clip (Figure 9-6), tighten.

Warm Air Intake

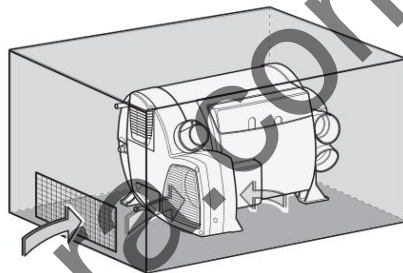

Figure 10

The warm air intake is drawn in by the heater. There must be a total area between the room and the heater not less than 150cm² opening.

Ensure that the warm air intake is not contaminated by the engine or heater exhaust, if necessary, with structural isolation measures.

Warm Air Distribution

Most of the warm air is imported into the floor area of the living compartment through the bellows.

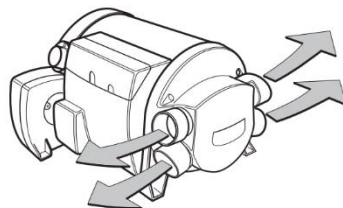

Figure 11

The four air outlets on the heater are connected to the $\phi 65$ bellows. Use only pressure piping that meets

the quality requirements of the Belief. Other pipes that do not meet our quality standards (especially wind resistance, pipe diameter and number of ripples) shall not be used. If the warm air duct must withstand a considerable amount of bending immediately after the hot air outlet of the heater in a limited space, we recommend using a 90° elbow (Figure 3-37). This elbow can be connected to a diameter of mm hot air duct.

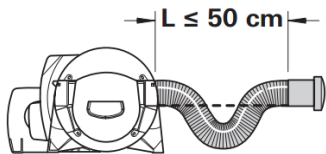

Figure 12

In the case where the length of the pipe is less than 2 meters, the air outlet cannot be installed at a height higher than the connection of the warm air duct. When the pipe length is less than 50cm, the pipe must be siphon between the connector and the outlet. These measures prevent the undesirable heating caused by (fairing effect) convection of the vehicle during summer operation.

★ The warm air pipe must be firmly inserted into the connection port.

To get the best warm air distribution, Belief recommends using 4 warm air outlets for the heater. If only three warm air outlets are required, then a lower warm air outlet must be selected to seal.

★ The Reset button

To heater

8

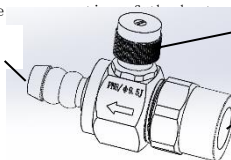

the analogue.

To liquefied gas

pressure regulating

Gas Connection

The heater operating pressure must be in compliance with a 30 Mbar liquefied gas supply.

When the gas pipe is cut off, clean the port flash and burrs.

The paving of the pipe must make the heater easy to disassemble for maintenance work.

Use high-pressure air to purge internal debris before installing the gas pipe.

The turning radius of the gas pipe is not less than R50, and it is recommended to use elbow pipe to pass the joint of right angle.

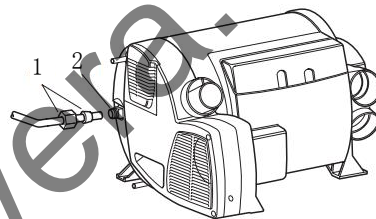

Figure 13

★ The gas interface (Figure 13-2) cannot be truncated or bent.

Before connecting to the heater, make sure that the gas line is free of dirt, shavings, etc.

The gas system must comply with the technical, administrative, and legal regulations of the country. Anti-collision safety valve (optional)

To ensure safety during driving, it is recommended to install a crash safety valve that must be installed after the liquefied gas tank regulator. when Impact, tilting, the anti-collision safety valve automatically cuts off the gas line.

Connecting Water Pipe

The water tank can be supplied with a pressure pump or immersion pump with a pressure of 2.8 bar.

If the tank is connected to a centralized water supply (rural or urban connection), or if a high-pressure pump is used, a pressure reducer must be used, which will prevent pressures above 2.8 bar.

★ The temperature rises and expansion of the water before the pressure relief valve is triggered may result in pressures up to 4.5 bar (may also occur with the immersion pump). Connected to the water tank and safe/the water pipe of the drain valve must be safe for drinking water, withstand pressure (up to 4.5 bar) and heat-resistant water up to 80 ° C.

If an immersion pump is used, a check valve must be installed between the pump and the first branch (Figure 15-1). Observe the flow direction when installing the check valve.

Anti-freezing automatic waterproof device (Figure 15-4, optional), a mechanical safety drain valve. When there is a danger of frost it will automatically drain the water from the tank through the scupper. If there is excessive pressure in the system **the pressure will be automatically released intermittently through the pressure relief valve (Figure 15-8, optional).**

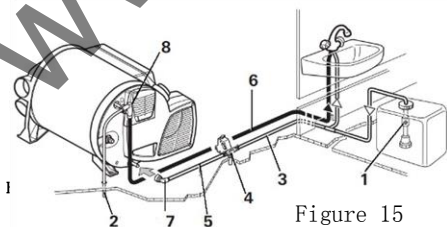

Figure 15

Install inside the vehicle and measure the room temperature. The sensor installation location is determined by the RV manufacturer based on the specific conditions of the vehicle. When selecting the installation location, please note that the external temperature sensor should not be subjected to direct heat radiation.

For optimum room temperature control, an external temperature sensor is installed above the entrance door.

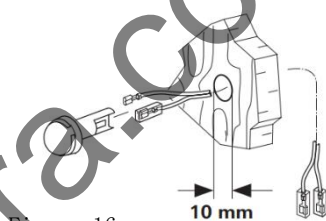

Figure 16

Make sure the external temperature sensor is always installed on the vertical wall. There must be free flowing air around it.

Drill a hole with a diameter of 10 mm. Single wire terminal passes through the opening from the back and connect the end of the cable to the sensor with an insulated connector plug (no need to observe polarity). Slide into the external temperature sensor and connect the two ends of the cable and the two insulated connectors to the heater electronics (if necessary, extend the cable to a maximum length of 10 meters, 2 x 0.5mm² cable).

The external temperature sensor provided must always be connected or the heater will switch to malfunction.

LCD Control Switch Installation

The gas heater must be operated with a dedicated LCD switch. See the relevant instructions for details.



When the window switch is not installed, the short connecting wire cannot be removed.

All cables connected to the heater must be hung in the direction of sagging. This will prevent condensate water slipping off from the connector cable and into the heater.

Figure 17

Electrical Connection

Lay the wires to avoid scratches. If there is a sharp edge, if the metal panel is threaded, use a lead bushing or edge protection accessory.

The connector cable must not be attached or in contact with metal surfaces, exhaust pipes or hot air ducts.

The electrical connector is located below the controller cover. The controller cover can be removed by pressing and simultaneously sliding in the direction of the arrow.

When removing or installing the controller cover, make sure that the connecting cable is not pulled out or squeezed.

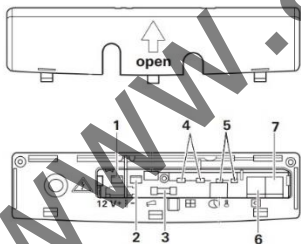

Figure 18

- 1-DC12V positive 2-DC12V negative
- 3-Fuse 4-Window Switch
- 5-External Temperature sensor
- 6, 7- Control switch

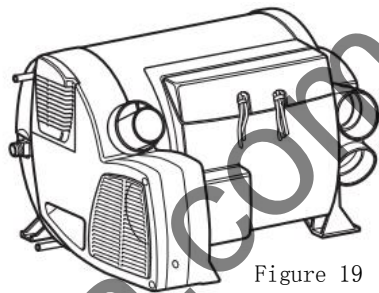

Figure 19

The connector cable and plug must be free of force.

Bundling connector cable (See Figure 20), attach it to the housing with a cable tie to eliminate tension. all cables must be securely connected and must not be loose or disconnected due to vibrations, causing a fire hazard!

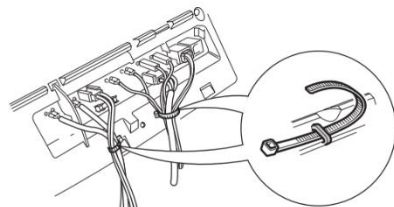

Figure 20

DC12V Power Supply

the heater's electrical wiring, switches, and control equipment must be in locations that would not adversely affect its operation under normal operating conditions.

The heater has reverse polarity protection. If the controller is not connected correctly, the LED indicator will not work.

To ensure the best power supply, the heater must be connected to the vehicle power supply (or battery) protected by the fuse (10A) with a 2 x 2.5 mm² cable (2 x 4 mm² for lengths over 6 meters).

If necessary, the voltage drop of the power supply line must be considered. Connect the negative line to the main ground line.

If the heater is directly connected to the battery, the positive and negative lines must be protected.

do not connect other power consuming devices.

www.avtovera.com

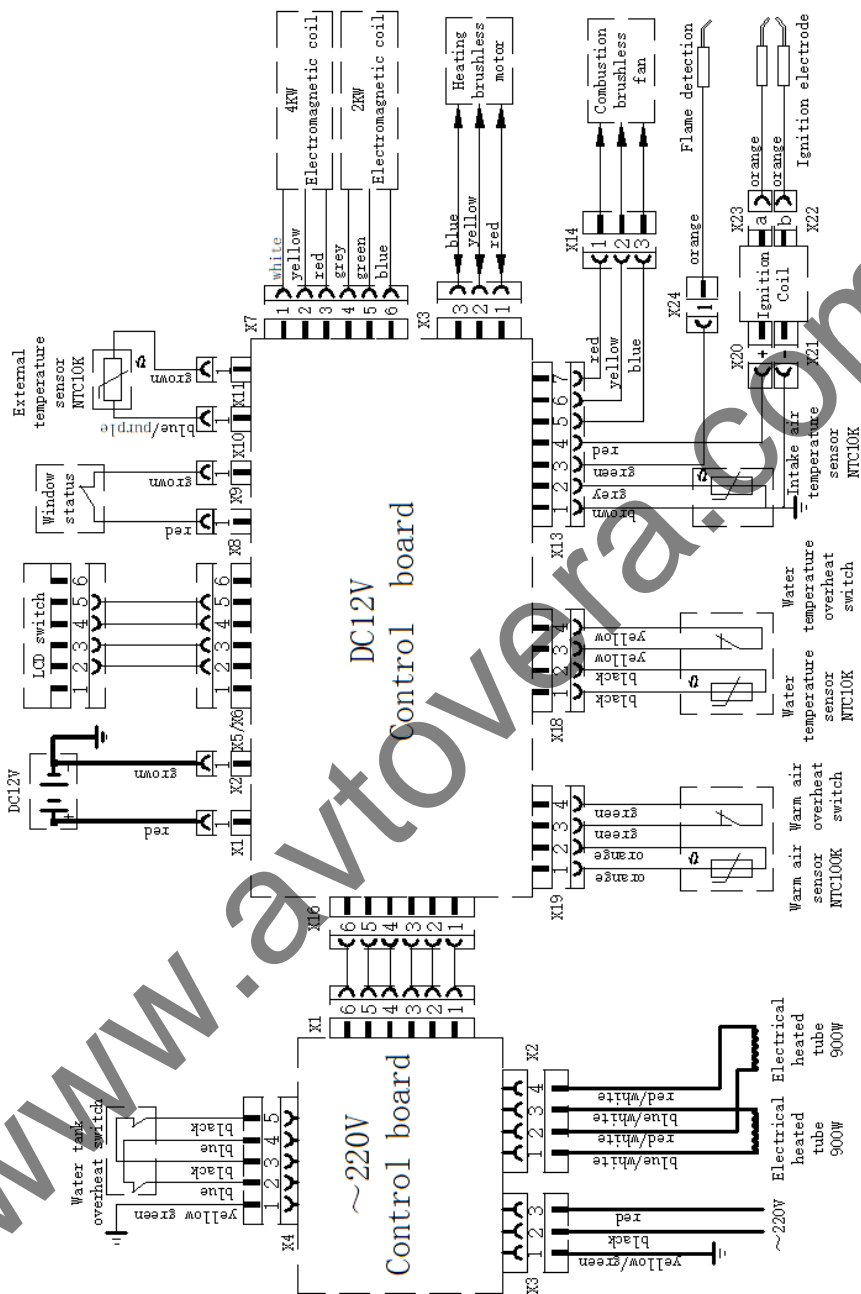

Figure 21

6. Operational Precautions

Gas heating is not permitted during refueling or in confined spaces (closed parking lots, workshops or ferry cabin).

Regularly check that the intake and exhaust pipes are in good condition and that the fixing is reliable, especially after a trip. Also check the fixing of the intake and exhaust pipes and the exhaust cowl.

When a black smoke occurs, must be inspected and repaired by professionals authorized by the company!

Make sure that the exhaust pipe at the exhaust cowl and intake pipe are unobstructed, and there are no obstructions such as snow mud, ice accretion, and leaves. The warm air outlet and the circulating air inlet are unobstructed to prevent the heater from overheating. Under overheating the overheat switch will immediately cut off the gas supply.

If the gas heater is to meet the heating needs during driving, a safety shut-off device should be installed.

★If without a safety shut-off device, the liquefied gas tank valve must be shut off before the driving.

12V Fuse

replace only with the exact same fuse T10A.

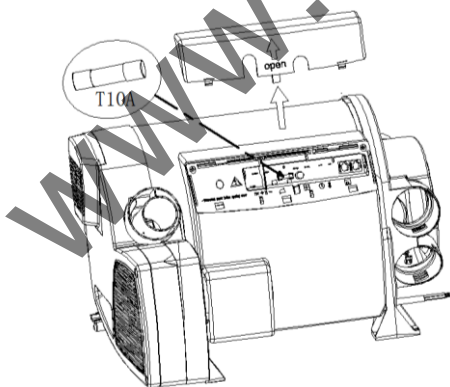

Figure 22

★ Fuse and Wire harness must be replaced by professionals authorized by the company.

★ All power must be disconnected before opening the control enclosure.

fuse specification: T10A slow fusing

Figure 23

~220V Overheat Protection

The electrical heating function has a mechanical overheat protection switch.

If the 12V power supply is interrupted during heating or after the heating process, the heater residual heat triggers the overheat protection switch.

After the water tank temperature has dropped, remove the controller cover and press the reset button to reset the overheat protection switch.

7. Operating Instructions

Please read the operating instructions carefully

before proceeding.

Start the Heater

Use a dedicated LCD switch to operate.

the main unit heating uses gas, electric, hybrid mode, heating water tank or not heating water tank are set as needed.

Check the power supply capacity of the RV camp and select the 900W (3.9A) or 1800W (7.8A) working mode.

- Check if the exhaust cowl is unobstructed
- Opening liquefied gas tank valve
- Water tank filled with water when needed

Switch Off the Heater

- Use a dedicated LCD switch to operate.
- After the heater is turned off, the combustion-supporting fan and the heating fan will continue to operate for a few minutes depending on the temperature of the furnace.

In case of freezing hazard, the water tank must be emptied.

- Close the circulating water pump
- Turn on the hot water tap in the kitchen and bathroom

★ Check the water with a 10L bucket to ensure that the tank is empty.

the liquefied gas tank valve must be shut off when the heater is not in use for long time or before driving.

6. Failure

6.1 General Failure Handling

6.1.1 During the use of the heater, it may appear that it cannot start normally or turn off itself after starting and is in the fault lock state. At this time, the heater can be turned off for more than 5S and restart.

6.1.2 The heater may cause circuit failure due to the following reasons: the connector is rusted, the poor contact, the plug is incorrect, the wire or fuse is rusted, the battery pile is rusted, etc.

Pay attention to inspection, maintenance and prevent these phenomena from occurring during use.

6.1.3 When the following conditions occur, it can be handled and eliminated by the user:

- The heater does not start after the power is turned on and the LCD switch screen does not light. The reason is that the fuse is open, or the wiring is wrong. In addition, check whether the plug on the LED switch lead wire is properly connected to the host.

6.2 Fault Lock Status

6.2.1 The fault generated by the heater is indicated by the fault code on the LED switch.

6.2.2 The faults can be eliminated according to the methods listed in Table 2.

Fault Lock Status Debug Method		
Fault Code	Fault Name	Fault Debug Method
10	Overvoltage fault	a. Check vehicle power supply system
11	Under voltage fault	a. Check vehicle power supply system
21	Warm air outlet temperature sensor disconnection	a. Check if the sensor is in good condition
22	Warm air outlet temperature sensor short circuit	a. Check if the sensor is in good condition
23	Water temperature sensor disconnection	a. Check if the sensor is in good condition
24	Water temperature sensor short circuit	a. Check if the sensor is in good condition
25	External temperature sensor disconnection	a. Check if the sensor is in good condition
26	External temperature sensor short circuit	a. Check if the sensor is in good condition
27	Combustion support temperature sensor disconnection	a. Check if the sensor is in good condition
28	Combustion support temperature sensor short circuit	a. Check if the sensor is in good condition
31	Combustion failure	a. Check gas supply system b. Check whether combustion inlet and outlet are blocked c. Check the Ignition coil, ignition electrode, flame sensor

Table 2

Fault Lock Status Debug Method		
Fault Code	Fault Name	Fault Debug Method
32	Combustion failure	<ul style="list-style-type: none"> a. Check gas supply system b. Check whether combustion inlet and outlet are blocked c. Check the flame sensor
33	Flame sensor fault	<ul style="list-style-type: none"> a. Check the flame sensor lead wire b. Check the flame sensor
41	Warm air outlet overheats	<ul style="list-style-type: none"> a. Check whether air outlet is blocked
42	Warm air overheats switch protection.	<ul style="list-style-type: none"> a. Check whether air outlet is blocked b. Check warm air overheat switch
43	Water overheat	<ul style="list-style-type: none"> a. Check whether water depletion in the tank b. Check if the sensor is in good condition c. Check whether air outlet is blocked
44	Water overheat switch protection.	<ul style="list-style-type: none"> a. Check whether air outlet is blocked b. Check water overheat switch
45	Overheating fault	<ul style="list-style-type: none"> a. Check whether air outlet is blocked b. Check water temperature sensor c. Check warm air sensor
51	Communication fault	<ul style="list-style-type: none"> a. Check interconnecting cable
71	Gas valve failure	<ul style="list-style-type: none"> a. Check gas valve coil and lead wire
72	Gas valve power failure	<ul style="list-style-type: none"> a. Replacement motherboard
81	Combustion support fan disconnection	<ul style="list-style-type: none"> a. Check combustion air blower
82	Combustion support blower boot failure	<ul style="list-style-type: none"> a. Check the blower motor lead wire b. Check combustion air blower
83	Combustion support blower spindle speed too low	<ul style="list-style-type: none"> a. Check combustion air blower motor
84	Warm air blower motor disconnection	<ul style="list-style-type: none"> a. Check warm air blower motor
85	Warm air blower motor boot failure	<ul style="list-style-type: none"> a. Check the blower motor lead wire b. Check warm air blower motor
86	Warm air blower spindle speed too low	<ul style="list-style-type: none"> a. Check warm air blower motor

Table 2 to continue

Fault Lock Status Debug Method		
Fault Code	Fault Name	Fault Debug Method
91	Ignition coil fault	a. Check ignition coil and lead wire
92	High voltage power supply fault	a. Replacement motherboard
93	High voltage power supply fault	a. Replacement motherboard
94	Gas valve power failure	a. Replacement motherboard
110	Window alarm	a. Check window switch interconnecting cable
120	Low voltage alarm	a. Recommended charging
220	220V No connection	a. Check alternating 220V power supply system

Table 2 to continue

www.avtovera.com

7. Operational Precautions

●Initial Installation

- Flush the water tank with clean water before the heater is first installed. When the heater is not in use, please vent the water tank to avoid freezing the water tank. The company is not responsible for damage to the water tank caused by freezing.

—Turn the circulating water pump on

— Turn on the hot water tap in the

Kitchen and bathroom, until the air is vented, and water tank is full, outgoing water is not discontinued

— Test run before the heater is used. Carefully check the leaks and safety conditions of all connections during the test run. If there is heavy smoke, abnormal combustion noise or gas odor, turn off the heater and unplug the fuse to make it inoperable. It can be used after being repaired by professionals.

- The odor may be emitted for a short time when the heater is used for the first time. This is normal for the first few minutes of the start of the run, it does not indicate that the heater is malfunctioning.

●Seasonal Maintenance

- Before each heating season, a special inspection must be carried out by a professional to carry out the following maintenance work:

Check the inlet and outlet of air for contamination and foreign matter.

Clean the external of heater

Check the circuit connections for rust and looseness.

Check whether the inlet and outlet of air is blocked or damaged.

Check if a gas leak occurs or smells of gas:

●Long-term halt

- When the heater is not used for a long time, it should

be run every 4 weeks for about 10 minutes each time to prevent the mechanical components such as solenoid valves and combustion air fans from malfunctioning (get stuck).

- The air inlet and outlet of the heater must be kept free from clogging and dirt, so that the warm air duct is unobstructed to prevent overheating.

●Heater Lifetime

- The heat exchanger of heater should not be used for more than 10 years. After expiration, it must be replaced with genuine parts and replaced by the heater manufacturer or its authorized agent.

- The exhaust pipe from which the heater emits exhaust gas must be renewed with genuine parts when the usage time reaches 10 years.

- It is the responsibility of the operator to replace the gas pressure regulator and gas line on a regular basis (by expiration date).

Other Operational Precautions

- **The tank must be descaled regularly, at least twice a year.**

- During the transportation and storage process, the ambient temperature of the heater should not exceed $-40^{\circ}\text{C} \sim 85^{\circ}\text{C}$ to prevent damage to electronic components.

- Only authorized customer service stations are allowed to install and repair heaters, and non-original parts are prohibited from danger.

- The heater is damaged due to installation and operation not according to the instruction, and the manufacturer is not responsible for the warranty.

Must shut-off the heater before refueling

- When performing electric welding on a car, first remove the positive line of the heater from the battery and ground it to prevent damage to the controller.

www.avtovera.com

Maintenance Record

Date	Repaired Items and Reason
Month Day Year	
Month Day Year	
Month Day Year	
Month Day Year	
Month Day Year	
Month Day Year	
Month Day Year	
Month Day Year	
Month Day Year	
Month Day Year	
Month Day Year	
Month Day Year	
Month Day Year	

www.avtovera.com



Harbin Haoke Science and Technology Co., Ltd.

Phone: 0451-82530666

0451-86676788

0451-86676988

Fax: 0451-82537683

Address: No. 9 Xingnan Road, Nangang District, Harbin, China

E-mail: haoke-sales@bilaiifu.com

Website: www.bilaiifu.com

Postcode: 150086



22020202400